

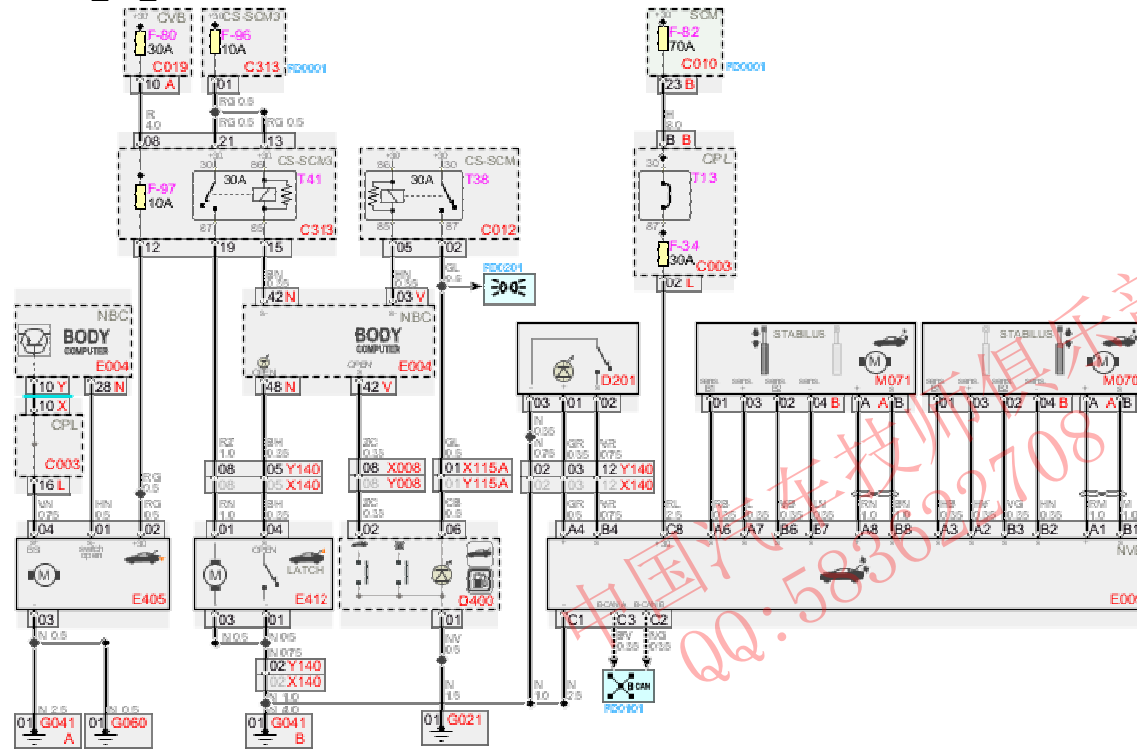

FD0424_00_P00 - 行李箱打开



FD0424 - 行李箱打开

Europe



0 - 999999



零件号	说明	电缆
E405	行李箱撞针托板执行器	C21211_1
E405	行李箱撞针托板执行器	C21211_1
E405	行李箱撞针托板执行器	C21211_1
E405	行李箱撞针托板执行器	C21211_1
C012	辅助保险丝和继电器 ECU (CS-SCM)	C31103_2
C012	辅助保险丝和继电器 ECU (CS-SCM)	C31103_2
C012	辅助保险丝和继电器 ECU (CS-SCM)	C31103_2
G021	乘客舱左后侧接地	C21211_2
G021	乘客舱左后侧接地	C21211_2
D400	行李箱盖和燃油加注口活门释放操纵装置	C21211_2
D400	行李箱盖和燃油加注口活门释放操纵装置	C21211_2
E412	中央锁行李箱锁	C47001_0
E412	中央锁行李箱锁	C47001_0
E004-V	车身计算机节点 (NBC)	C31103_2
E004-V	车身计算机节点 (NBC)	C31103_2
E004-V	车身计算机节点 (NBC)	C31103_2
E004-N	车身计算机节点 (NBC)	C21211_2
E004-N	车身计算机节点 (NBC)	C21211_2
E004-N	车身计算机节点 (NBC)	C21211_2
E004-N	车身计算机节点 (NBC)	C21211_2
E004-N	车身计算机节点 (NBC)	C21211_2
E004-N	车身计算机节点 (NBC)	C21211_2
E004-N	车身计算机节点 (NBC)	C21211_2
E004-N	车身计算机节点 (NBC)	C21211_2
E004-N	车身计算机节点 (NBC)	C21211_2
C313	辅助继电器 ECU 3 (CS-SCM 3)	C21211_1
C313	辅助继电器 ECU 3 (CS-SCM 3)	C21211_1
C313	辅助继电器 ECU 3 (CS-SCM 3)	C21211_1
C313	辅助继电器 ECU 3 (CS-SCM 3)	C21211_1
C313	辅助继电器 ECU 3 (CS-SCM 3)	C21211_1
X115-A	乘客舱电缆和后部线路/前部线路和乘客舱电缆之间的连接	C31103_2
X115-A	乘客舱电缆和后部线路/前部线路和乘客舱电缆之间的连接	C31103_2
X115-A	乘客舱电缆和后部线路/前部线路和乘客舱电缆之间的连接	C31103_2
Y115-A	乘客舱电缆和后部线路/乘客舱电缆和后部线路之间的连接	C21211_2
Y115-A	乘客舱电缆和后部线路/乘客舱电缆和后部线路之间的连接	C21211_2

中国汽车技术俱乐部
QQ: 583622508

Y115-A	乘客舱电缆和后部线路/乘客舱电缆和后部线路之间的连接	C21211_2
Y140	行李箱电缆/乘客舱电缆和后部线路之间的连接点	C47001_0
Y140	行李箱电缆/乘客舱电缆和后部线路之间的连接点	C47001_0
X140	乘客舱电缆和后部线路/行李箱电缆之间的连接点	C21211_1
X140	乘客舱电缆和后部线路/行李箱电缆之间的连接点	C21211_1
X140	乘客舱电缆和后部线路/行李箱电缆之间的连接点	C21211_1
X140	乘客舱电缆和后部线路/行李箱电缆之间的连接点	C21211_1
X140	乘客舱电缆和后部线路/行李箱电缆之间的连接点	C21211_1
X140	乘客舱电缆和后部线路/行李箱电缆之间的连接点	C21211_1
X140	乘客舱电缆和后部线路/行李箱电缆之间的连接点	C21211_1
X008	乘客舱电缆和后部线路/乘客舱电缆和后部线路之间的连接	C31103_2
X008	乘客舱电缆和后部线路/乘客舱电缆和后部线路之间的连接	C31103_2
X008	乘客舱电缆和后部线路/乘客舱电缆和后部线路之间的连接	C31103_2
Y008	乘客舱电缆和后部线路/前部线路和乘客舱电缆之间的连接	C21211_2
Y008	乘客舱电缆和后部线路/前部线路和乘客舱电缆之间的连接	C21211_2
Y008	乘客舱电缆和后部线路/前部线路和乘客舱电缆之间的连接	C21211_2
G041-B	后部接地 - 左侧	C21211_1
G041-B	后部接地 - 左侧	C21211_1
Y140	行李箱电缆/乘客舱电缆和后部线路之间的连接点	C47001_0
Y140	行李箱电缆/乘客舱电缆和后部线路之间的连接点	C47001_0
X140	乘客舱电缆和后部线路/行李箱电缆之间的连接点	C21211_1
X140	乘客舱电缆和后部线路/行李箱电缆之间的连接点	C21211_1
X140	乘客舱电缆和后部线路/行李箱电缆之间的连接点	C21211_1
X140	乘客舱电缆和后部线路/行李箱电缆之间的连接点	C21211_1
X140	乘客舱电缆和后部线路/行李箱电缆之间的连接点	C21211_1
X140	乘客舱电缆和后部线路/行李箱电缆之间的连接点	C21211_1
X140	乘客舱电缆和后部线路/行李箱电缆之间的连接点	C21211_1
G041-A	后部接地 - 左侧	C21211_1
G041-A	后部接地 - 左侧	C21211_1
G060	燃油箱接地	C21211_1
G060	燃油箱接地	C21211_1
C313	辅助继电器 ECU 3 (CS-SCM 3)	C21211_1
C313	辅助继电器 ECU 3 (CS-SCM 3)	C21211_1
C313	辅助继电器 ECU 3 (CS-SCM 3)	C21211_1
C313	辅助继电器 ECU 3 (CS-SCM 3)	C21211_1
C313	辅助继电器 ECU 3 (CS-SCM 3)	C21211_1
E004-Y	车身计算机节点 (NBC)	CA0101_0
E004-N	车身计算机节点 (NBC)	C21211_2
E004-N	车身计算机节点 (NBC)	C21211_2
E004-N	车身计算机节点 (NBC)	C21211_2
E004-N	车身计算机节点 (NBC)	C21211_2
E004-N	车身计算机节点 (NBC)	C21211_2

E004-N	车身计算机节点 (NBC)	C21211_2
E004-N	车身计算机节点 (NBC)	C21211_2
E004-N	车身计算机节点 (NBC)	C21211_2
C003-L	仪表板ECU (CPL)	C21211_2
C003-L	仪表板ECU (CPL)	C21211_2
C003-L	仪表板ECU (CPL)	C21211_2
C003-L	仪表板ECU (CPL)	C21211_2
C003-L	仪表板ECU (CPL)	C21211_2
C003-L	仪表板ECU (CPL)	C21211_2
C003-L	仪表板ECU (CPL)	C21211_2
C003-L	仪表板ECU (CPL)	C21211_2
C003-X	仪表板ECU (CPL)	CA0101_0
C019-A	行李箱 ECU (CVB)	C21211_1
C019-A	行李箱 ECU (CVB)	C21211_1
C019-A	行李箱 ECU (CVB)	C21211_1
C019-A	行李箱 ECU (CVB)	C21211_1
C019-A	行李箱 ECU (CVB)	C21211_1
C019-A	行李箱 ECU (CVB)	C21211_1
C019-A	行李箱 ECU (CVB)	C21211_1
D201	行李箱盖按钮	C47001_0
D201	行李箱盖按钮	C47001_0
E009	电动尾门 ECU	C21211_1
E009	电动尾门 ECU	C21211_1
E009	电动尾门 ECU	C21211_1
E009	电动尾门 ECU	C21211_1
E009	电动尾门 ECU	C21211_1
E009	电动尾门 ECU	C21211_1
E009	电动尾门 ECU	C21211_1
Y140	行李箱电缆/乘客舱电缆和后部线路之间的连接点	C47001_0
Y140	行李箱电缆/乘客舱电缆和后部线路之间的连接点	C47001_0
X140	乘客舱电缆和后部线路/行李箱电缆之间的连接点	C21211_1
X140	乘客舱电缆和后部线路/行李箱电缆之间的连接点	C21211_1
X140	乘客舱电缆和后部线路/行李箱电缆之间的连接点	C21211_1
X140	乘客舱电缆和后部线路/行李箱电缆之间的连接点	C21211_1
X140	乘客舱电缆和后部线路/行李箱电缆之间的连接点	C21211_1
X140	乘客舱电缆和后部线路/行李箱电缆之间的连接点	C21211_1
X140	乘客舱电缆和后部线路/行李箱电缆之间的连接点	C21211_1
M071-A	Stabilus 减震器弹簧 - 左侧	C21211_1
M071-A	Stabilus 减震器弹簧 - 左侧	C21211_1
M071-A	Stabilus 减震器弹簧 - 左侧	C21211_1
M071-B	Stabilus 减震器弹簧 - 左侧	C21211_1
M071-B	Stabilus 减震器弹簧 - 左侧	C21211_1
M071-B	Stabilus 减震器弹簧 - 左侧	C21211_1

中国汽车技术俱乐部
QQ:583627108

M071-B	Stabilus 减震器弹簧 - 左侧	C21211_1
M070-A	Stabilus 减震器弹簧 - 右侧	C21211_1
M070-A	Stabilus 减震器弹簧 - 右侧	C21211_1
M070-A	Stabilus 减震器弹簧 - 右侧	C21211_1
M070-B	Stabilus 减震器弹簧 - 右侧	C21211_1
M070-B	Stabilus 减震器弹簧 - 右侧	C21211_1
M070-B	Stabilus 减震器弹簧 - 右侧	C21211_1
C003-L	仪表板ECU (CPL)	C21211_2
C003-L	仪表板ECU (CPL)	C21211_2
C003-L	仪表板ECU (CPL)	C21211_2
C003-L	仪表板ECU (CPL)	C21211_2
C003-L	仪表板ECU (CPL)	C21211_2
C003-L	仪表板ECU (CPL)	C21211_2
C003-L	仪表板ECU (CPL)	C21211_2
C003-B	仪表板ECU (CPL)	C31103_2
C010-B	保险丝 ECU 和发动机舱继电器 (SCM)	C31103_2
C010-B	保险丝 ECU 和发动机舱继电器 (SCM)	C31103_2
C010-B	保险丝 ECU 和发动机舱继电器 (SCM)	C31103_2
C010-B	保险丝 ECU 和发动机舱继电器 (SCM)	C31103_2

中国汽车技师俱乐部
QQ:583622708



C21211_1 - 乘客舱电缆和后部电缆

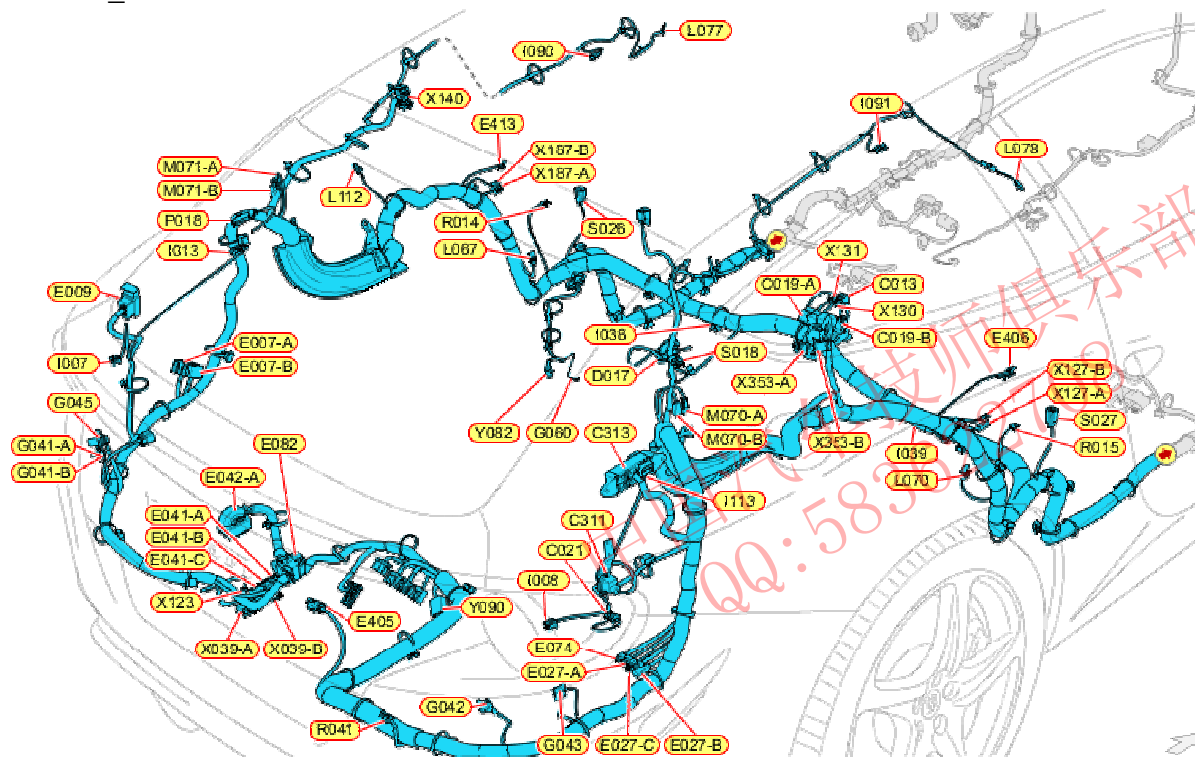

零件号	说明	电缆
G041-A	后部接地 - 左侧	C21211_1
M070-B	Stabilus 减震器弹簧 - 右侧	C21211_1
C313	辅助继电器 ECU 3 (CS-SCM 3)	C21211_1
G060	燃油箱接地	C21211_1
M070-A	Stabilus 减震器弹簧 - 右侧	C21211_1
E009	电动尾门 ECU	C21211_1
M071-A	Stabilus 减震器弹簧 - 左侧	C21211_1
M071-B	Stabilus 减震器弹簧 - 左侧	C21211_1
C019-A	行李箱 ECU (CVB)	C21211_1
G041-B	后部接地 - 左侧	C21211_1

X140
E405

乘客舱电缆和后部线路/行李箱电缆之间的连接点
行李箱撞针托板执行器

C21211_1
C21211_1

中国汽车技师俱乐部
QQ:583622708



C31103_2 - 前部电缆和乘客舱电缆

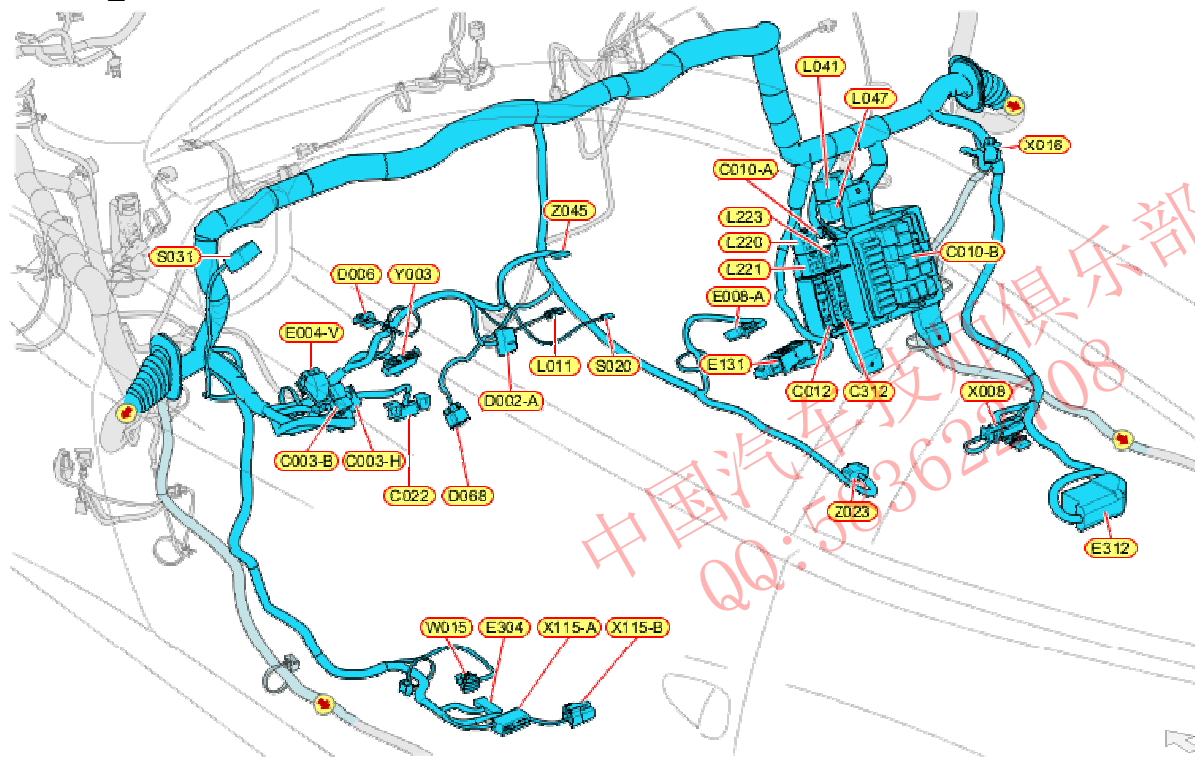

零件号	说明	电缆
C003-B	仪表板ECU (CPL)	C31103_2
C010-B	保险丝 ECU 和发动机舱继电器 (SCM)	C31103_2
X115-A	乘客舱电缆和后部线路/前部线路和乘客舱电缆之间的连接	C31103_2
X008	乘客舱电缆和后部线路/乘客舱电缆和后部线路之间的连接	C31103_2
C012	辅助保险丝和继电器 ECU (CS-SCM)	C31103_2
E004-V	车身计算机节点 (NBC)	C31103_2



C21211_2 - 乘客舱电缆和后部电缆

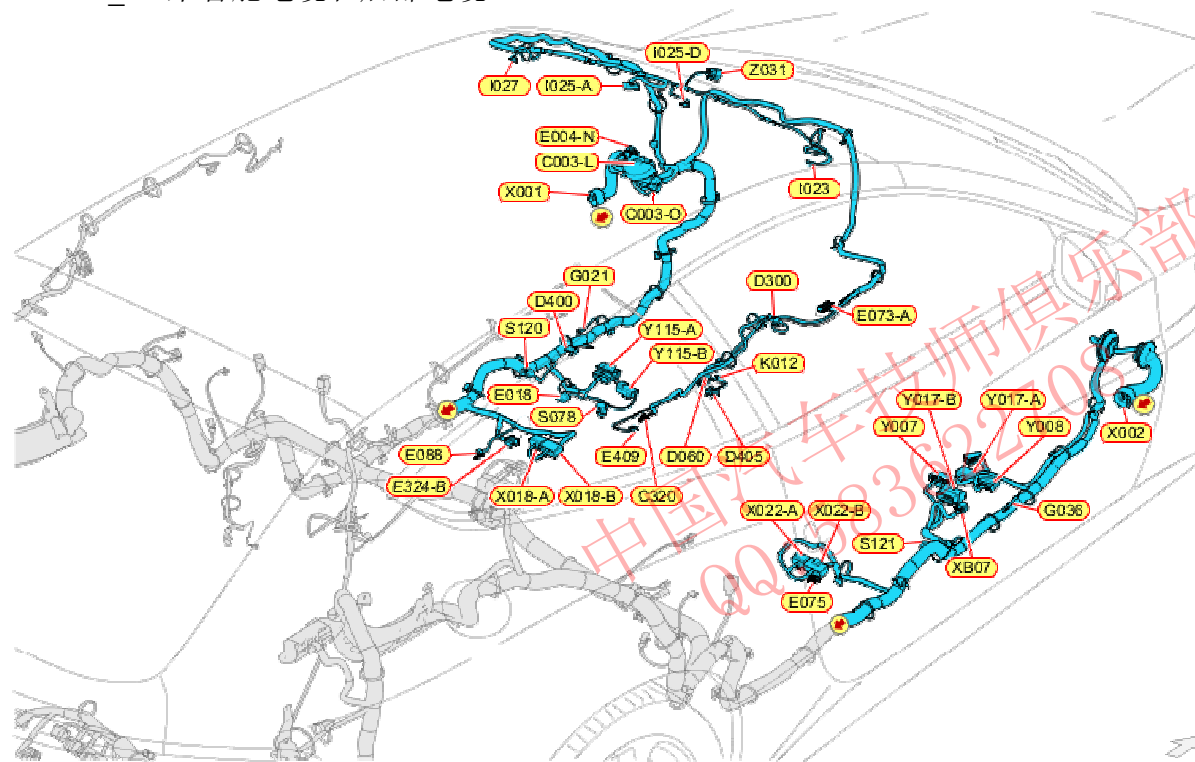

零件号	说明	电缆
Y115-A	乘客舱电缆和后部线路/乘客舱电缆和后部线路之间的连接	C21211_2
C003-L	仪表板ECU (CPL)	C21211_2
D400	行李箱盖和燃油加注口活门释放操纵装置	C21211_2
Y008	乘客舱电缆和后部线路/前部线路和乘客舱电缆之间的连接	C21211_2
G021	乘客舱左后侧接地	C21211_2
E004-N	车身计算机节点 (NBC)	C21211_2



C47001_0 - 行李箱盖电缆

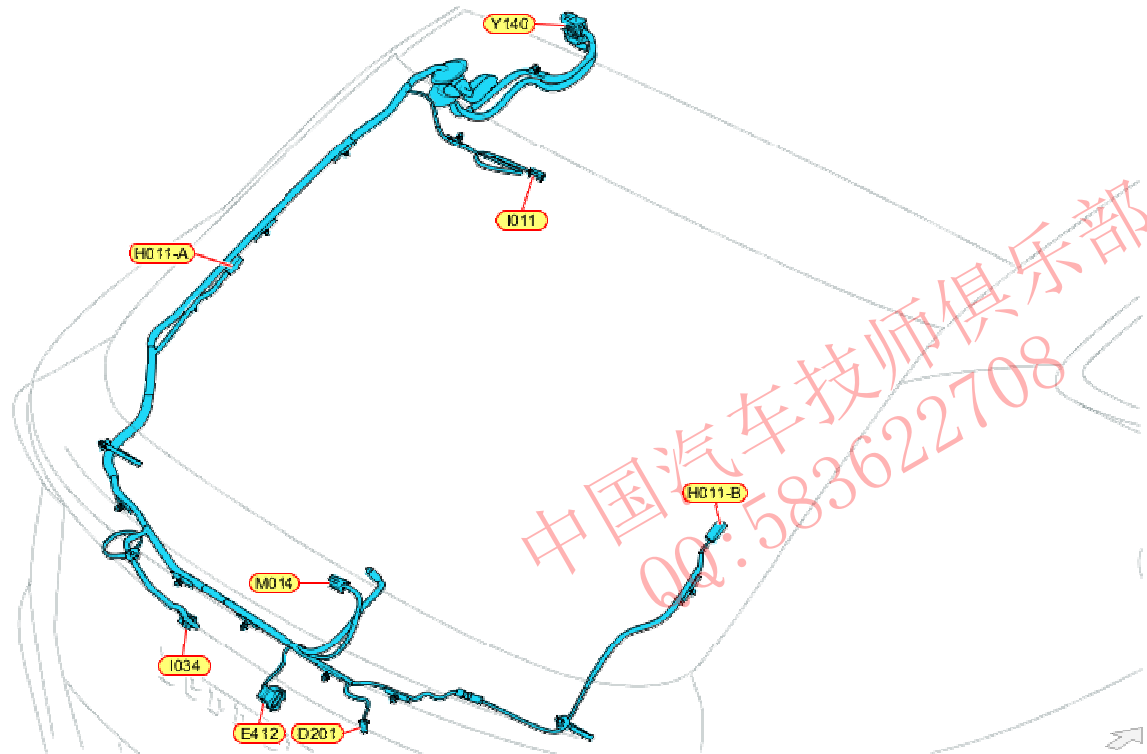

零件号	说明	电缆
Y140	行李箱电缆/乘客舱电缆和后部线路之间的连接点	C47001_0
E412	中央锁行李箱锁	C47001_0
D201	行李箱盖按钮	C47001_0



CA0101_0 - E004-Y C003-X

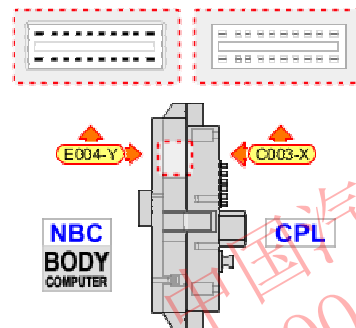

零件号	说明	电缆
C003-X	仪表板ECU (CPL)	CA0101_0
E004-Y	车身计算机节点 (NBC)	CA0101_0

FD0424 - 行李箱打开

Europe



0 - 999999



E405

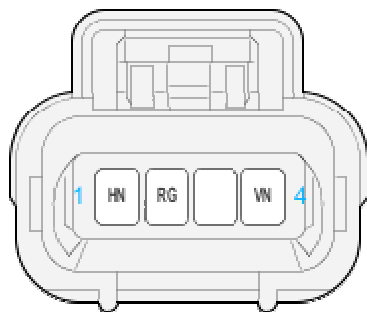

E405

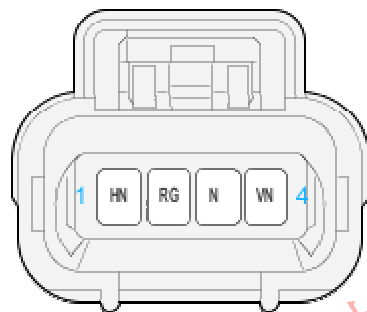

E405

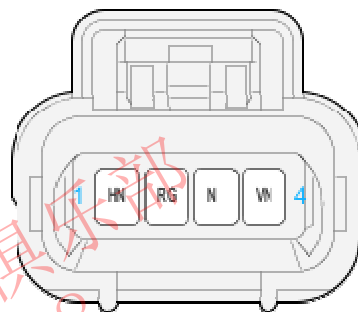

C012

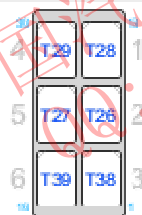

CS-SCM

C012

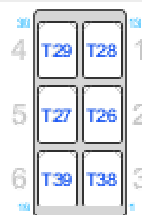

CS-SCM

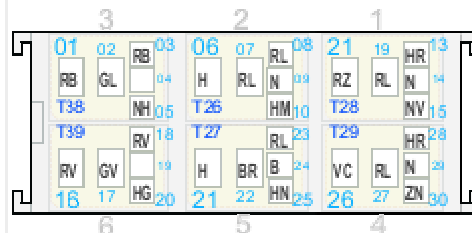
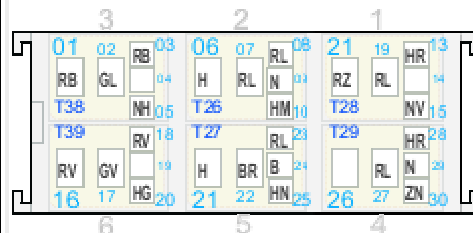

C012

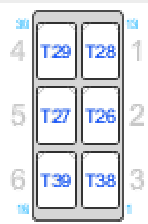

CS-SCM

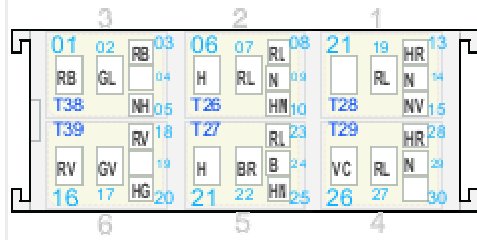

G021

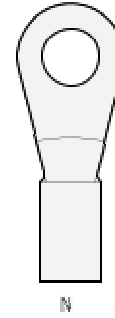

中国汽车技师俱乐部
 QQ:583622708



D400

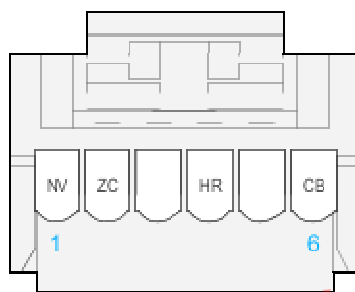

E412

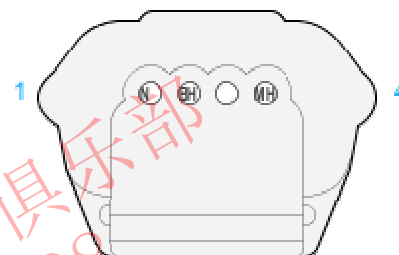

E412

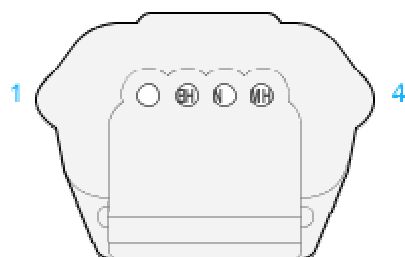

E004-V

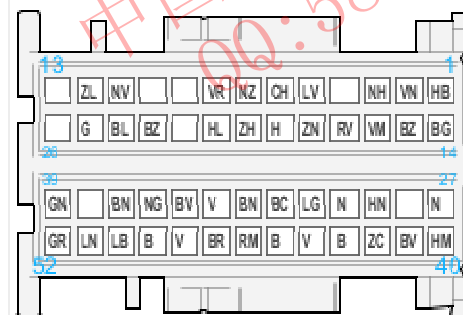

E004-V

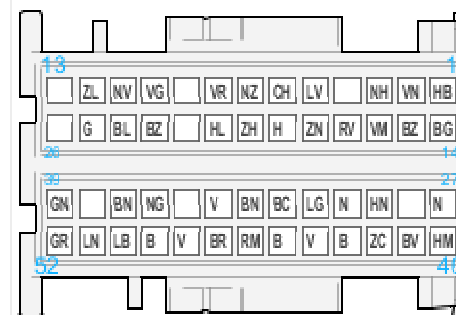

中国汽车技师俱乐部
QQ: 583622708

E004-V

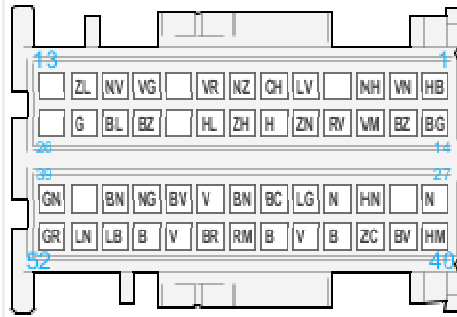

E004-N

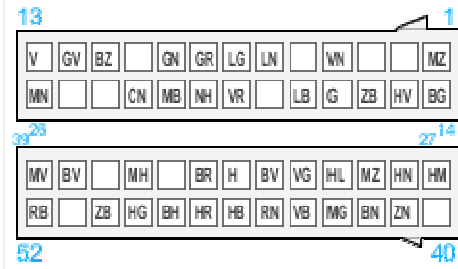

E004-N

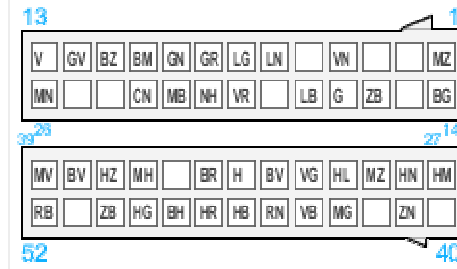

中国汽车技师俱乐部
QQ:583622708

FD0424 - 行李箱打开

Europe



0 - 999999



E004-N

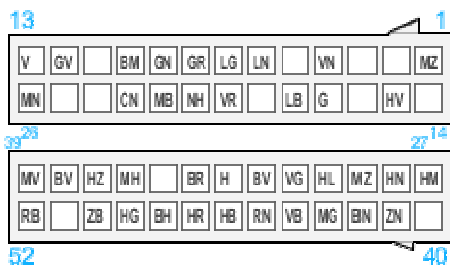

E004-N

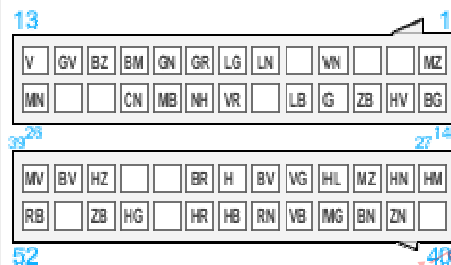

E004-N

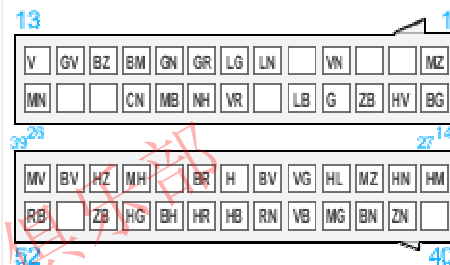

E004-N

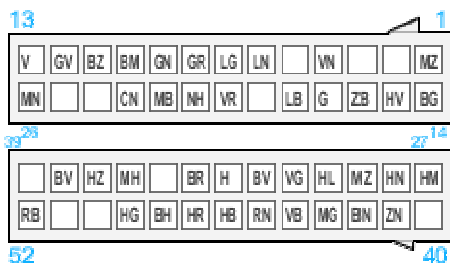

E004-N

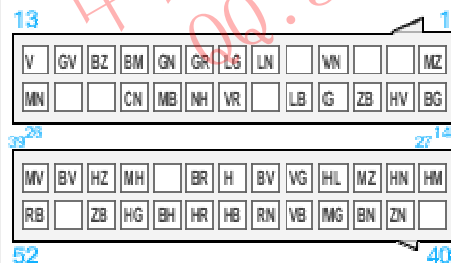

C313

CS-SCM3



C313

CS-SCM3



C313

CS-SCM3

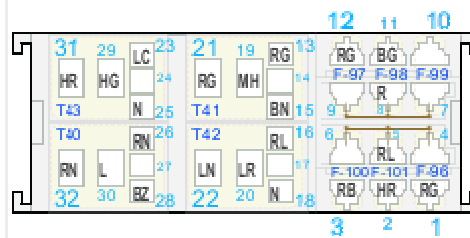
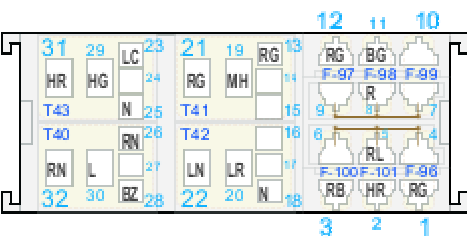
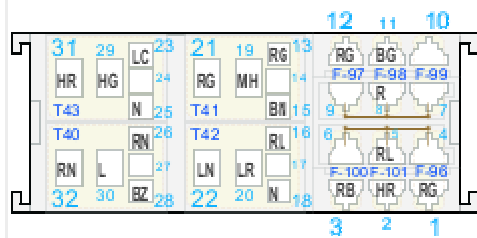
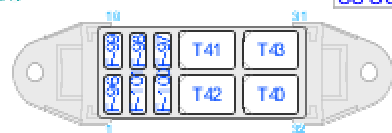

中国汽车技师俱乐部
 QQ: 583622708



C313

CS-SCM3



X115-A

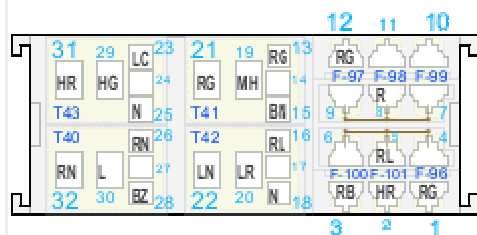
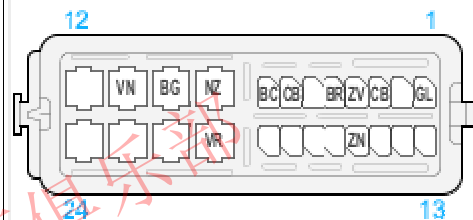

X115-A

X115-A

Y115-A

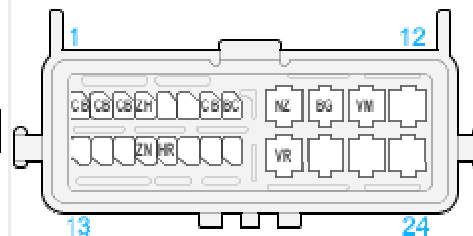
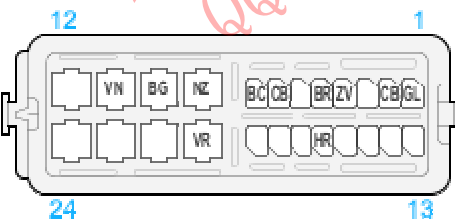
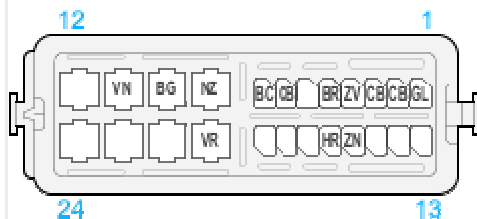

中国汽车技师俱乐部
QQ: 583622708

Y115-A

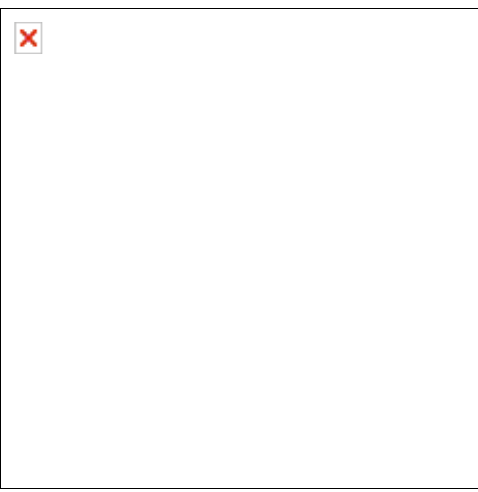
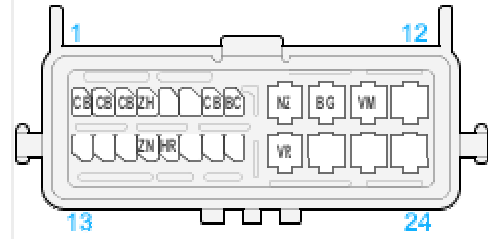

Y140

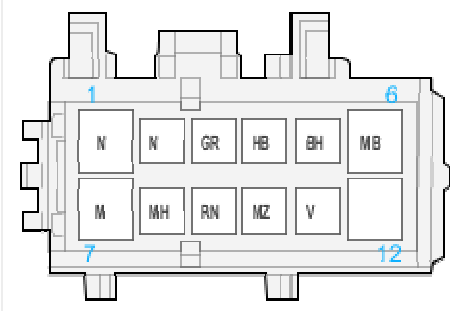

中国汽车技师俱乐部
QQ: 583622708



Y140

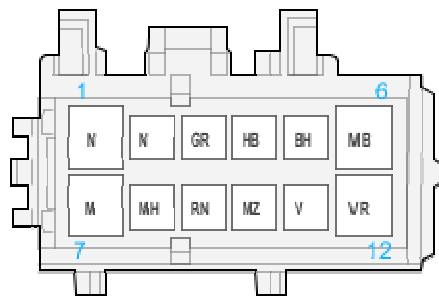

X140

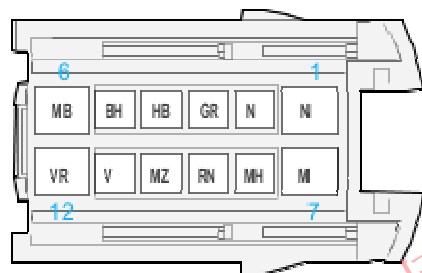

X140

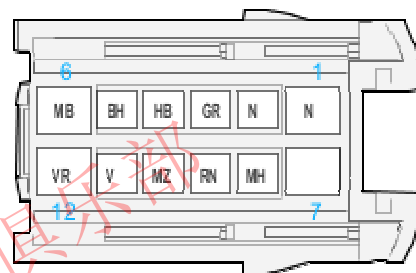

X140

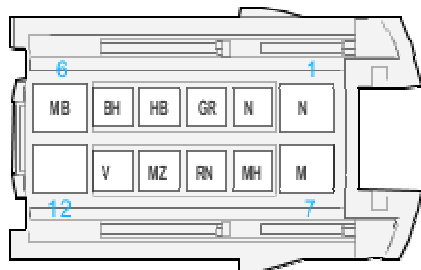

X140

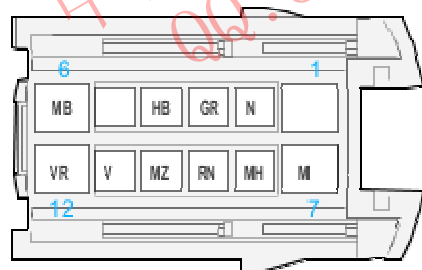

X140

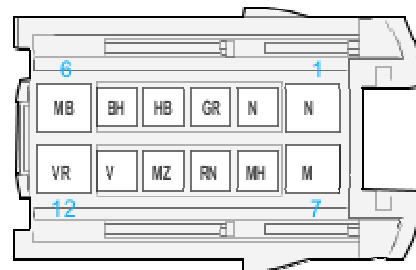

中国汽车技师俱乐部
QQ: 583622708

X140

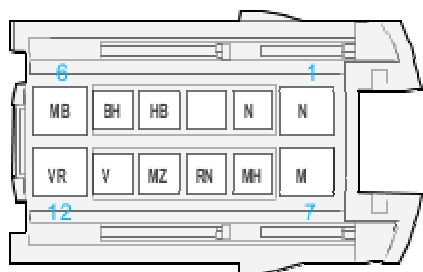

X

X008

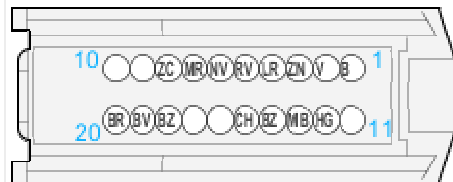

中国汽车技师俱乐部
QQ: 583622708



X008

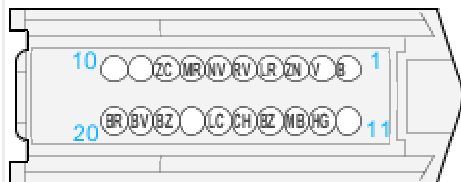

X008

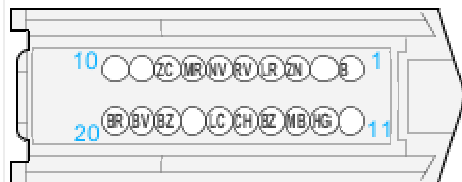

Y008

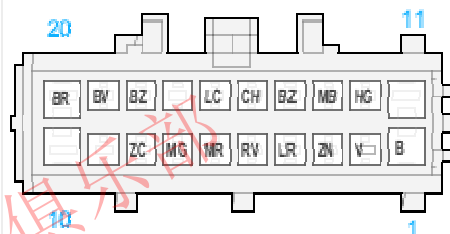

Y008

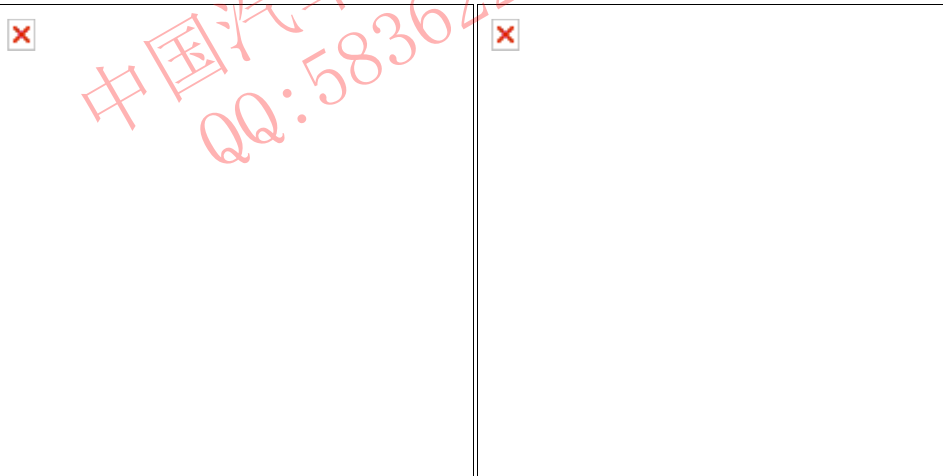
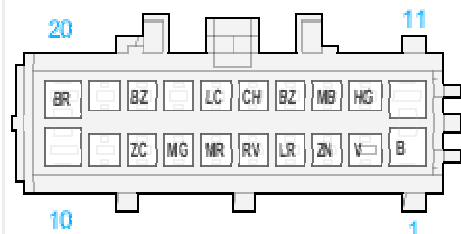

G041-B

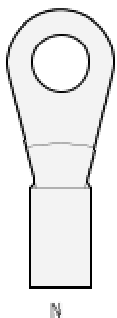

Y140

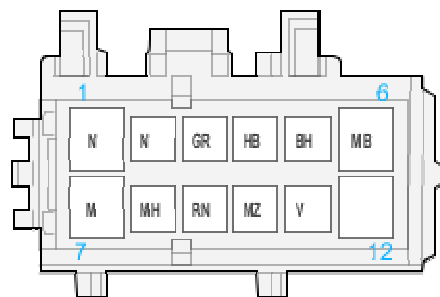

Y140

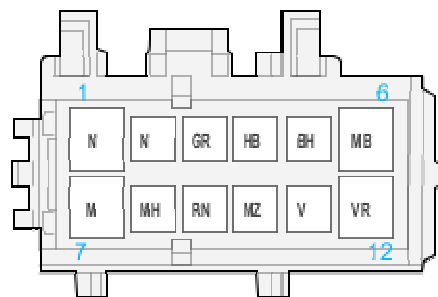

中国汽车技师俱乐部
QQ:583622708



X140

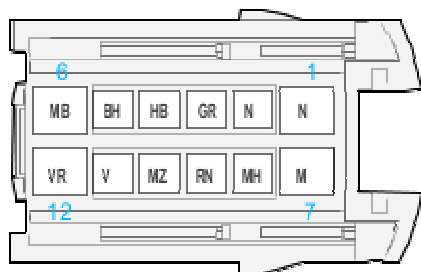

X140

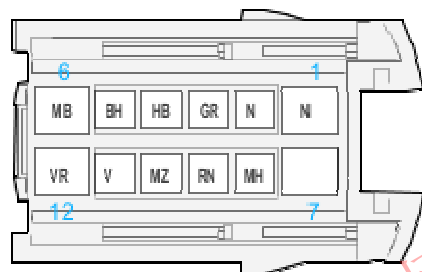

X140

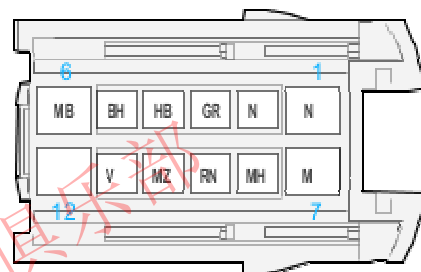

X140

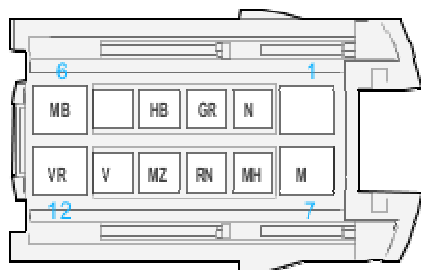

X140

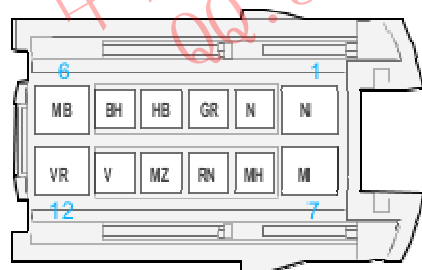

X140

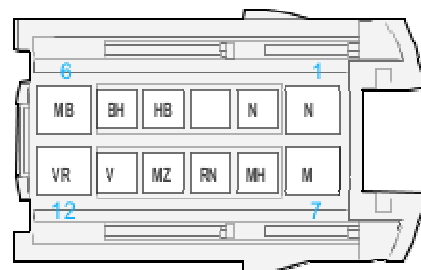

中国汽车技师俱乐部
QQ: 583622708

×

×

G041-A

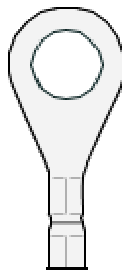

N

中国汽车技师俱乐部
QQ:583622708

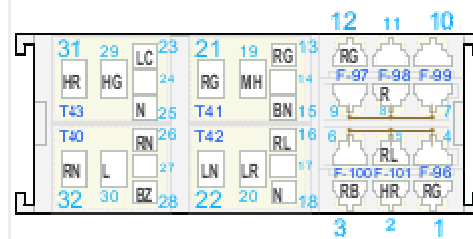
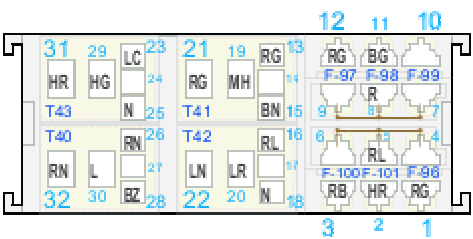
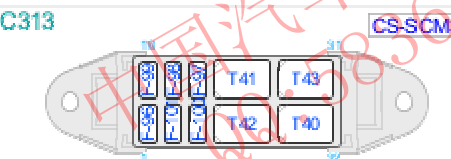
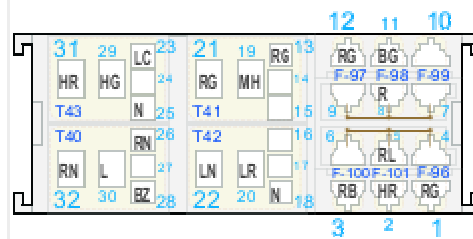
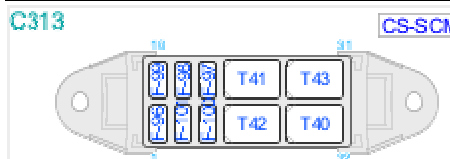
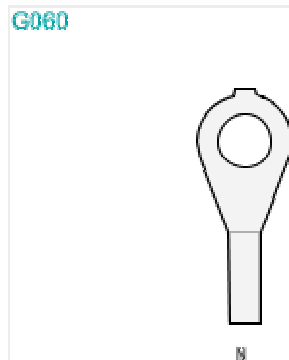
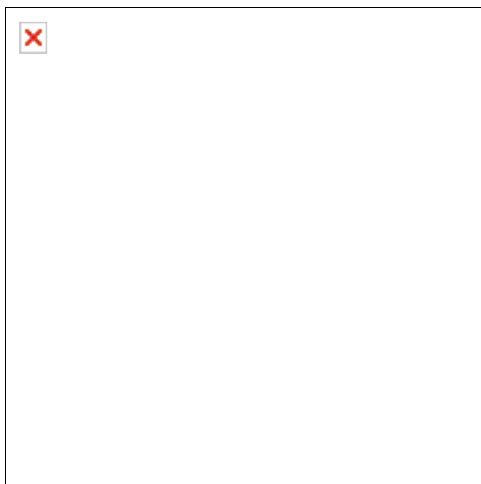

中国汽车技师网
www.china-cars.com
电话: 400-5856227



E004-Y

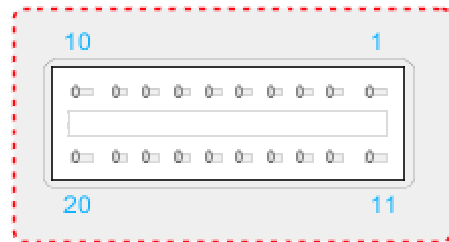

E004-N

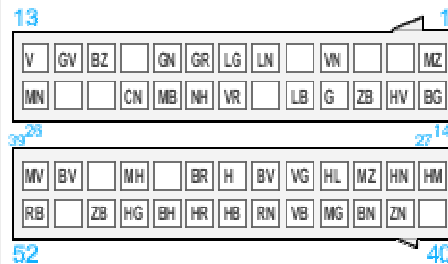

中国汽车技师俱乐部
QQ:583622708

FD0424 - 行李箱打开

Europe



0 - 999999



E004-N

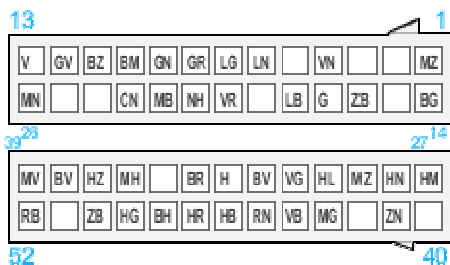

E004-N

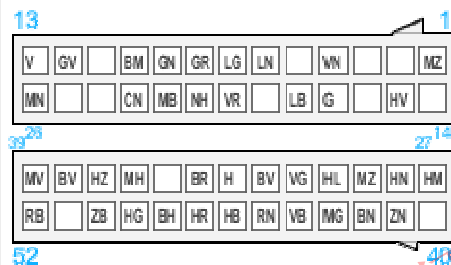

E004-N

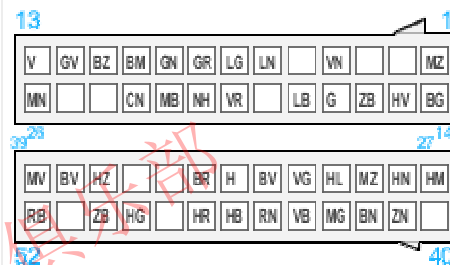

E004-N



E004-N

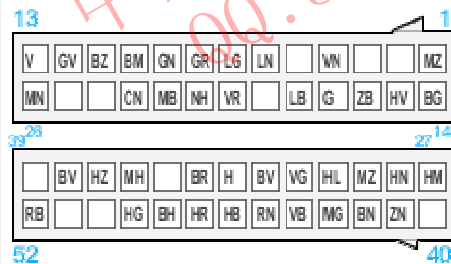

E004-N

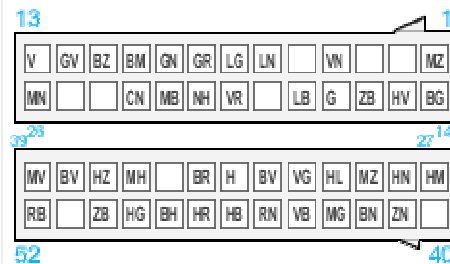

中国汽车技师俱乐部
QQ: 583622708



C003-L



C003-L



中国汽车技师俱乐部
QQ:583622708

FD0424 - 行李箱打开

Europe



0 - 999999



C003-L

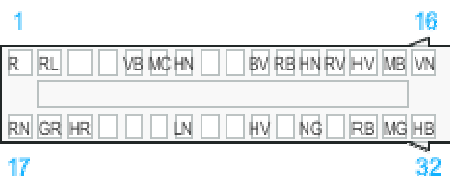

C003-L

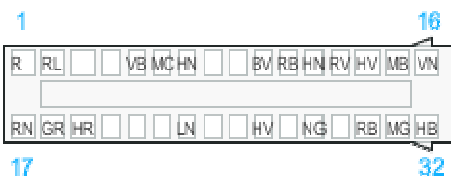

C003-L

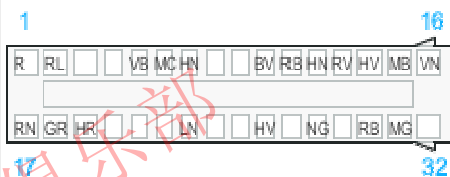

C003-L

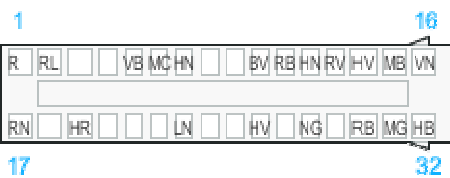

✘

中国汽车技师俱乐部
QQ:583622708

C003-X

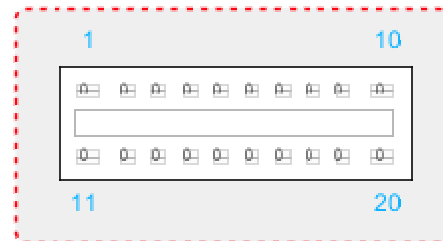

C019-A

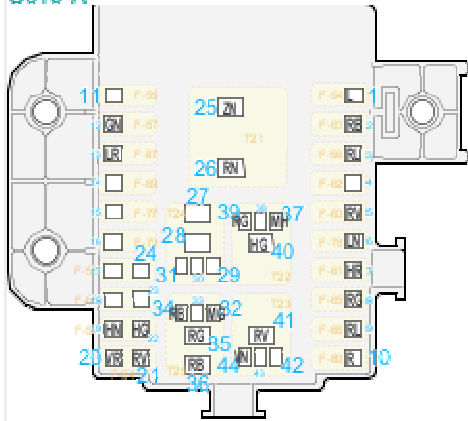

C019-A

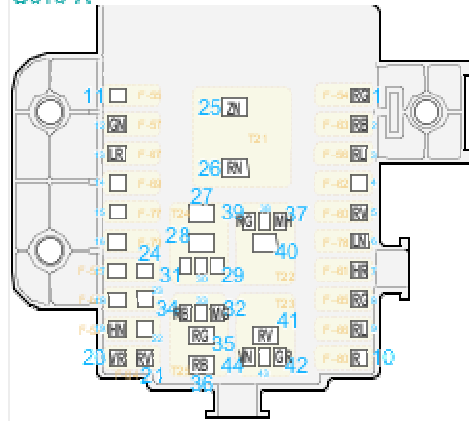

C019-A

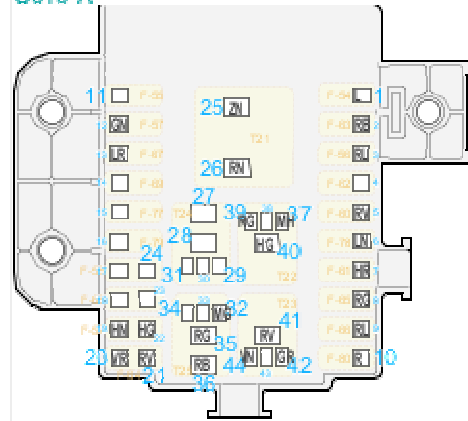

中国汽车技师俱乐部
 QQ: 583622708



C019-A

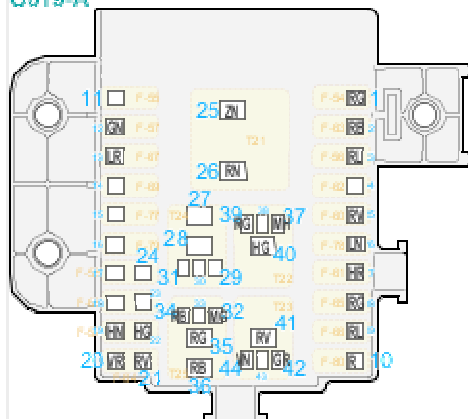

C019-A

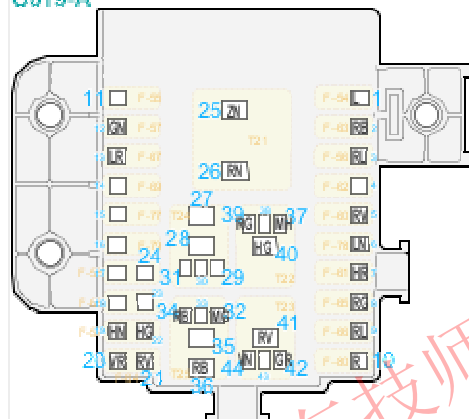

C019-A

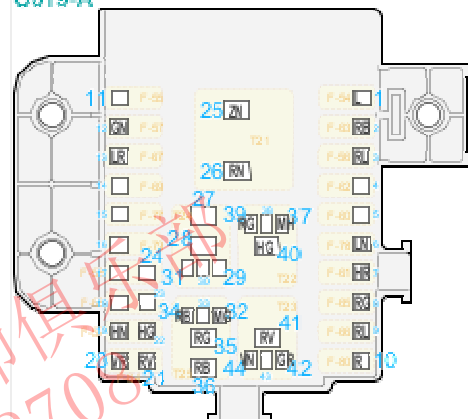

D201



D201

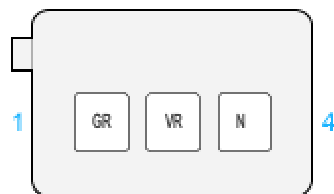

中国汽车技师俱乐部
QQ: 583622700

E009

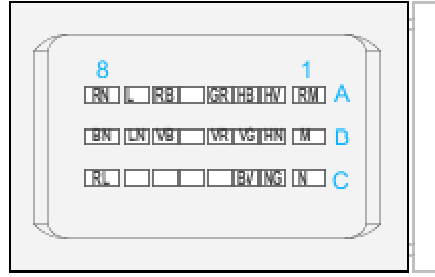

E009

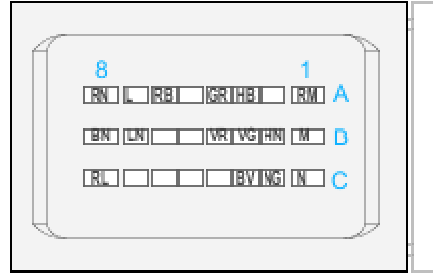

E009

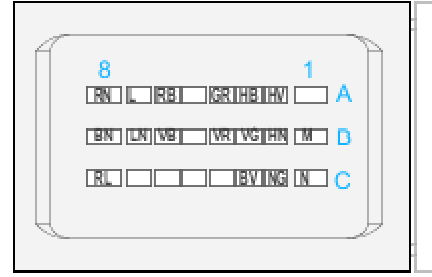

中国汽车技师俱乐部
QQ:583622708



E009

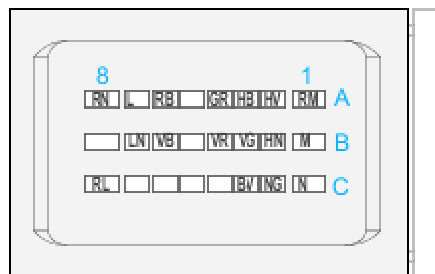

E009

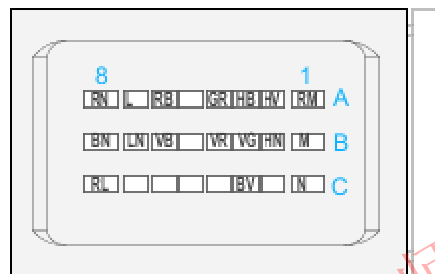

E009

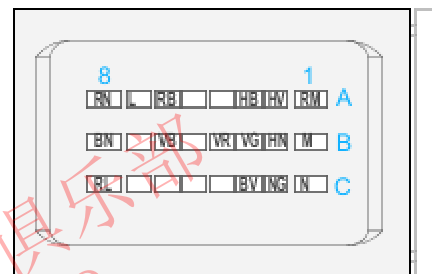

Y140

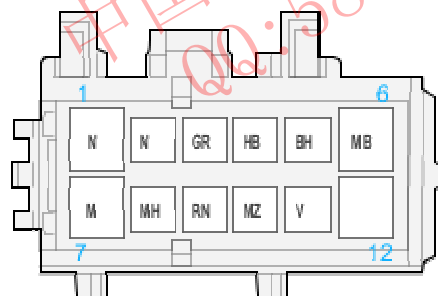

Y140

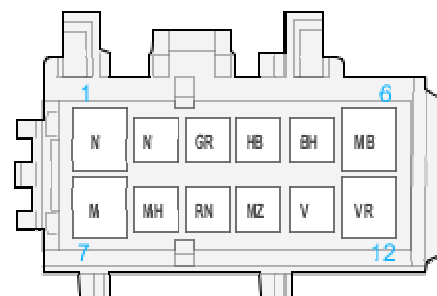

X140

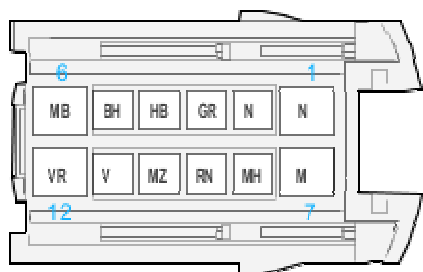

X140

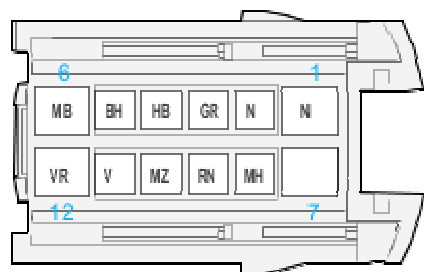

X140

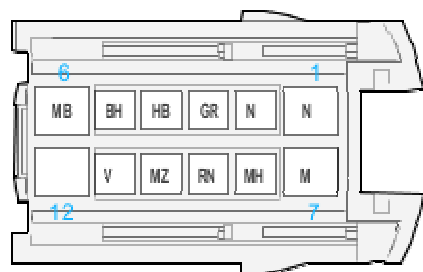

中国汽车技师俱乐部
QQ:583622708

FD0424 - 行李箱打开

Europe



0 - 999999



X140

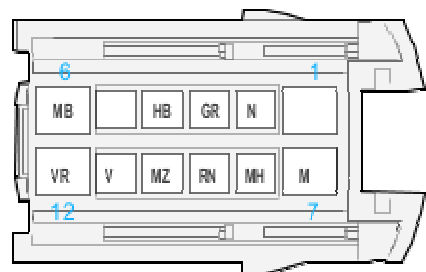

X140

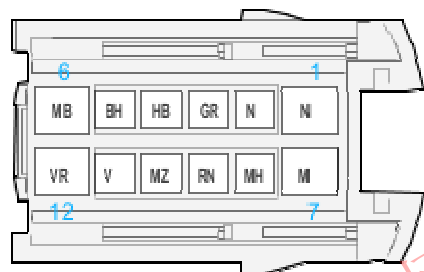

X140

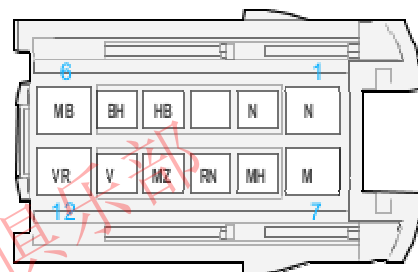

M071-A

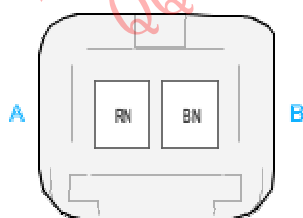

M071-A

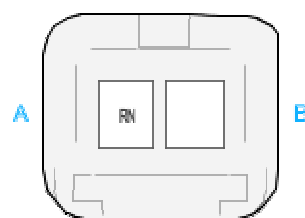

中国汽车技师俱乐部
QQ: 583622708



M071-B

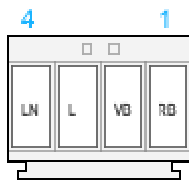

M071-B

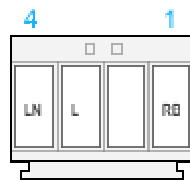

中国汽车技师俱乐部
QQ: 583622708



M071-B

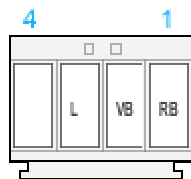

M070-A

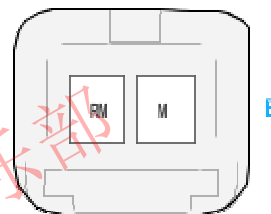

M070-A

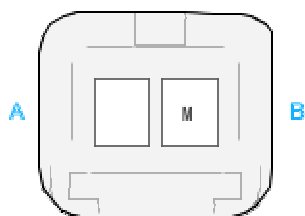

M070-B

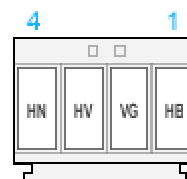

中国汽车技师俱乐部
QQ:583622708

M070-B

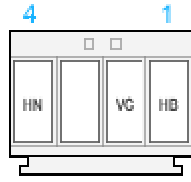

C003-L

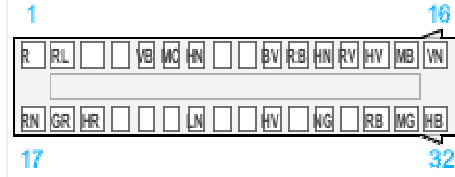

中国汽车技师俱乐部
QQ:583622708

FD0424 - 行李箱打开

Europe



0 - 999999



C003-L

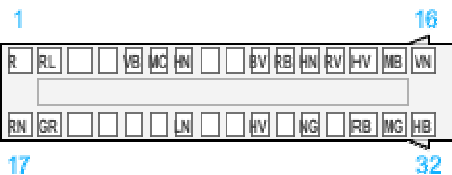

C003-L

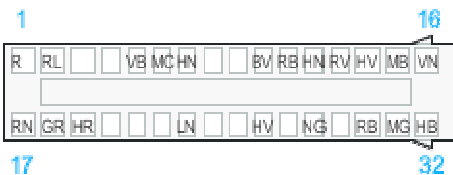

C003-L

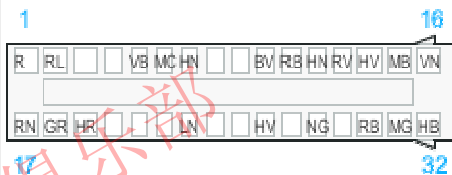

C003-L

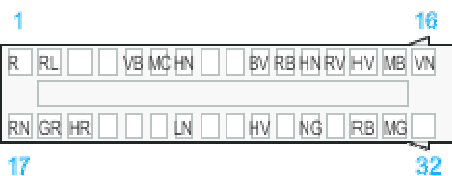

C003-L

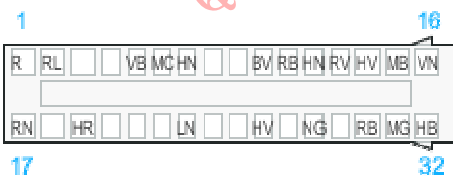

中国汽车技师俱乐部
 QQ: 583622708

C003-B

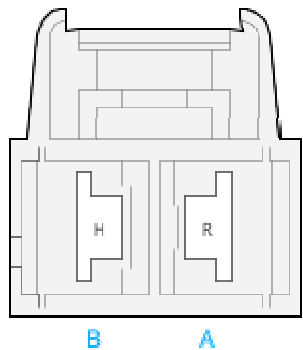

C010-B

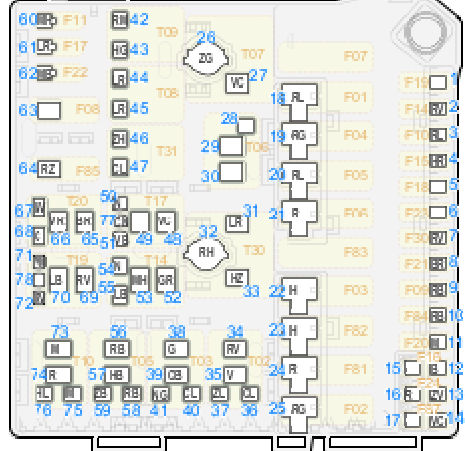

C010-B

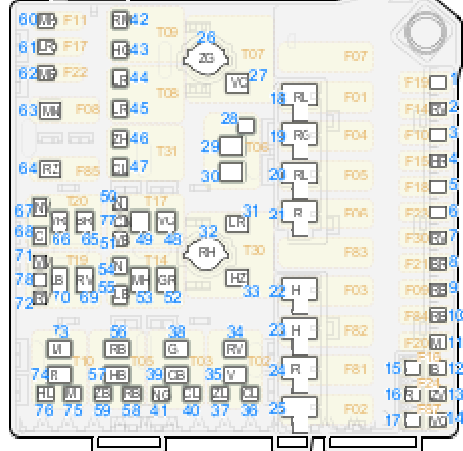

中国汽车技师俱乐部
QQ: 583622708

Copyright Ferrari S.p.A. - P.IVA 00159560366

FD0424 - 行李箱打开

Europe



0 - 999999



中国汽车技师俱乐部
QQ:583622708

